

**ITP-2**

**10.1" Industrial Tablet – Android based**



**Feature**

- Qualcomm® Snapdragon™ 6490 Octa core 2.2 GHz processor
- 1,000 nits; 1920 x 1200 Gorilla multi touch display
- Support glove/rain mode
- 5G/4G LTE, WiFi 802.11 ac, BT5.0 LE, GNSS (Dead-Reckoning optional)
- 9,060mAh (min. 8,680mAh) Hot swappable battery
- IP65, Operating Temp. -20°C ~ 60°C
- Two Expansion options (for MSR/SCR/UHF RFID)
- Android™ 13

**Specification**

**ITP-2**

<b>Display &amp; Touch Screen</b>	Panel Size	10.1 TFT LCD WUXGA (1920 x 1200), 1,000 nits
	Touch Panel	10-Point Capacitive Multi-Touch with Gorilla Glass, Sunlight readable, Glove/Rain Mode
	Stylus	Support 2mm Hard Tip Stylus
<b>Motherboard</b>	CPU	Qualcomm® Snapdragon™ Octa-Core 6490 processor
	OS	Android 13
	RAM / Flash	4GB LPDDR4 / 64GB eMMC
	Storage Expansion	microSD up to 64GB
	Camera	Front: 5MP; Rear: 13MP; Auto-Focus, Flash LED
<b>System</b>	1D/2D BCR	Optional
	NFC	13.56MHz, ISO14443 A/B, ISO 15693, MiFare, Felica
	Battery	9,060mAh (min. 8,680mAh) Hot Swap Battery, Fast Charging
	WWAN	5G/4G LTE
	SIM	Nano SIM x2
	GNSS	u-blox Neo-M8N (Neo-M8U optional, with Dead-Reckoning) support GPS/Glonass/Gallileo/Beidou/QZSS/SBAS
	WLAN	Wi-Fi 802.11a/b/g/n/ac/ax
	Bluetooth	Bluetooth 5.0 Class 2, BLE
	Speaker	Stereo
	Microphone	Front & Rear, with Acoustic Noise Cancellation
	Sensor	Ambient Light Sensor, Proximity, Accelerometer, Gyroscope & Magnetometer Sensor
	I/O	USB 3.1 Type-C (Alt Mode/OTG) x1, USB 2.0 Type A x2 Combo Audio Jack (Headphone & Microphone) x1 micro SD x1 RF Pass-Through x3 for WWAN/WLAN/GNSS
	Expansion I/O	Docking Connector x1; Expansion Connector x2
Power	USB3.2 Type C connector, support charging by power bank	
<b>Environment</b>	Temperature & Humidity	Operating Temp.: -20°C ~ 60°C; Storage Temp.: -30°C ~ 70°C
	Dust/Water Proof	IP65 (IEC60529)
	Drop	4 ft. on concrete, 5 ft. on plywood
	Safety	UL/CSA62368-1, 2 <sup>nd</sup> Ed.; IEC/EN62368-1
<b>Certification</b>	SAR	FCC 47 CFR2.1093; EN62311, EN62209-2; EN62209-1:201
	EMC	FCC Part 15B, Class B; CAN/CSA ICES-003, Class B; EN55032, Class B; EN301-489-1/-13/-17/-24/-52; EN61000-3-2; EN61000-3-3; EN55035
	RF	FCC Part 15C, 15E, 22H, 24E, 27L; CE RED EN 300 328, EN 301 893, EN 300 440, EN 303 413, EN 301 908-1/-2/-13, EN 301 511
	Environment	RoHS, WEEE
	Dimension (W x H x D)	280.0 x 195.0 x 18.8mm
<b>Dimension &amp; Weight</b>	Weight	1.1kg
	Vehicle Docking	USB 3.1 x2, GbE x1, RS-232 x1; (Vibration 5M3)
<b>Accessory</b>	Office Docking	USB 3.1 x2, GbE x1, RS-232 x1, HDMI x1, Line-out, Mic-in, Kensington Lock, Battery Charging Bay x1
	Expansion Module	Ethernet RJ-45, UART RS-232/422/485, UHF RFID, 3D ToF Camera, MSR, Smart Card Reader, Finger Print Scanner

### Expansion



### Expansion

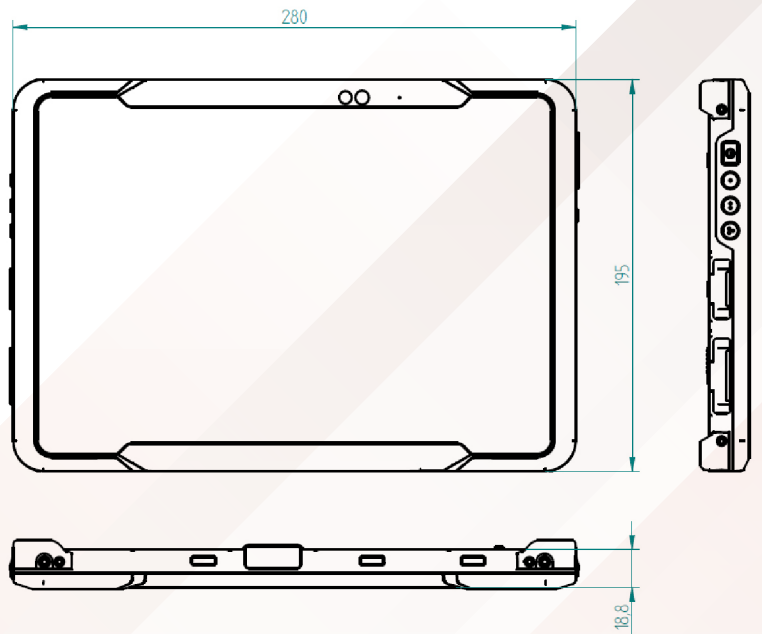

### 2 Expansion Slots for:

- Ethernet RJ 45
- UART RS 232/422/485
- Magnetic Stripe Reader
- IC Smart Card Reader

- 3D ToF Depth Camera
- Finger Print Reader
- UHF RFID Reader
- Customized Module

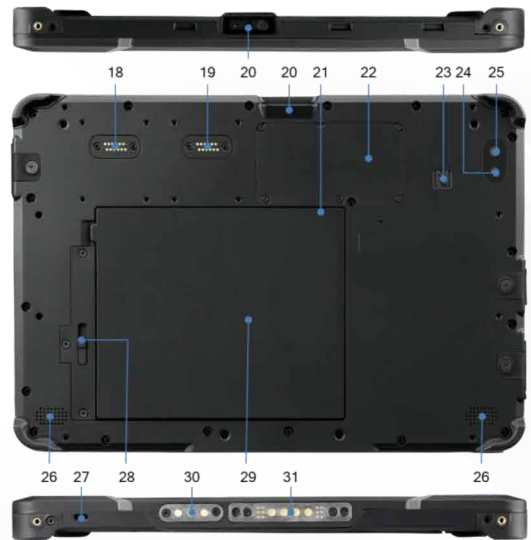

1. Power Button
2. F1 Function key
3. F2 Function key
4. F3 Function key
5. microSD Slot
6. Audio Jack
7. USB 2.0 Type-A
8. USB 3.0 Type-C

9. Status LED
10. 10.1" Touch Display
11. Ambient Light Sensor
12. 5MP Front Camera
13. Front Microphone
14. USB 2.0 Type-A
15. BCR Trigger
16. Volume +

17. Volume -
18. Expansion 1
19. Expansion 2
20. BCR (Barcode Reader)
21. SIM slot x2
22. Service Door
23. NFC / RFID
24. Flash LED

25. 13MP Rear Camera
26. Stereo Speaker
27. Kensington Lock
28. Battery Latch
29. Battery
30. RF Pogo
31. Main Pogo
32. Battery Gauge Button

